

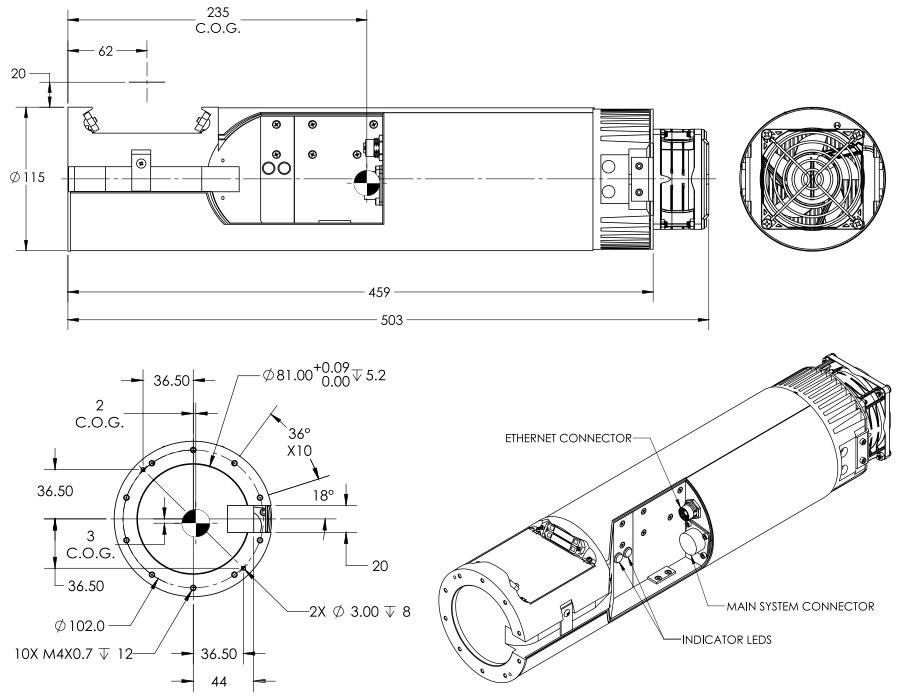

BeadScan-150 System

The Xiris BeadScan system is a Weld Bead Root Pass Monitoring System specifically designed to accurately scan, record (and optionally measure) the surface geometry and create a 2D visual image of a welded bead typically found on the back side of the root pass in a multi-pass weld process on pipes.

The BeadScan system is used to ensure the integrity of the root pass weld in applications that are difficult to see otherwise, and the data can be recorded and played back for off-line review for quality purposes or kept as a production reference in case any issues arise in the future. Suitable for large welding projects typically found in pipeline, ship building and pressure vessel manufacturing.



Class 3B laser light

Indirect eye exposure may cause injury. Do not insert any reflective objects into the path of the laser beam while it is operating.

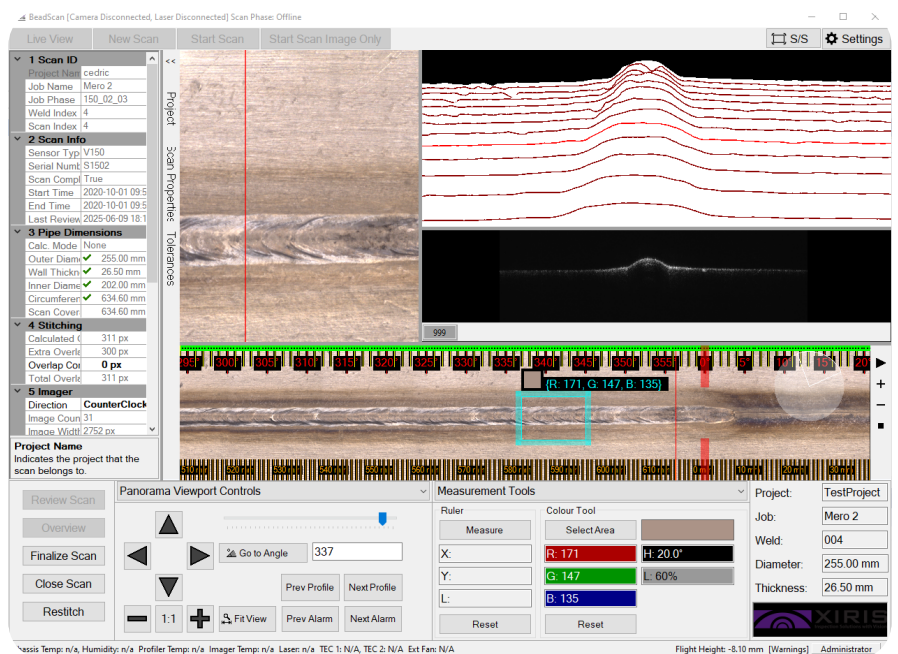

The BeadScan-150 system includes:

Sensor head hardware comprising of a high-resolution laser triangulation system and a high-resolution on-axis camera with its own specialized lighting. This is compact but needs to be mounted on a crawler device that would provide rotational position of the sensor, rotating it through 360 degrees of scanning.

An optimized software package that allows operating personnel to fully image, analyze, annotate and record each weld with an intuitive, easy to use interface. The surface geometry of the weld bead can be analyzed to determine if the first pass was properly welded with multiple optional measurements. In addition, a high resolution, on-axis 2D image is created that makes a complete visual recording of 360 degrees of the weld bead.

Key features include:

- Integrated sensor head with a low-profile design to fit inside a pipe with an ID of 150mm (6") or larger.
- Advanced optical design provides a large depth of field to ensure excellent image quality and accurate measurements across a large FOV with up to +/- 9 mm of bead depth variation.
- Powerful bespoke software to measure, analyse, annotate, and record weld profile and a 2D image of the complete weld profile.
- Ethernet connectivity for reliable high data transfer rates, up to 100meter (300ft) cable length.

Sensor Head

| | |
|--|--|
| Dimensions | 115 mm (D) x 501 mm (L) |
| Pipe Minimum Size to be Analysed | ID = 150 mm (6") or greater |
| Stand off height (from sensor to pipe wall) | 20mm |
| Depth of Focus | +/- 9 mm |
| Maximum Field of View | 29.5 mm (W) x 23.5 mm (V) |
| Operating Ambient Environment Storage Environment | 10°- 40° C (withTEC)-20 to +60° C |
| Ideal CycleTime | 1000 profiles per 6" inner diameter under 1 mm |
| Weight | Approximately 5 kg |
| Connections | M12 X-coded (Gb Ethernet) Suitable for up to 100m cable. Power & I/O connector: 20 Pin Circular |
| Camera Image Size | 2750 (W) x 2200 (H) pixels |
| Power | 24VDC, <20 A |
| Integrated Laser Line Generator | Class 3B |

Software

| | |
|--|---|
| Image Processing / AnalysisTools | Image Stitching / Digital Zoom / ColourTools / MeasurementTool / AnnotationTool |
| Weld Bead Measurements (Optional) | Mismatch / Bead Height / BeadWidth / Concavity / Undercut |
| Operating System | Windows® 11 (64 Bit) |

Xiris Automation Inc.

5046 Mainway, Unit 2
Burlington, ON L7L 5Z1
Canada
T: +1.905.331.6660 | F: +1.905.331.6661
E: sales@xiris.com

Xiris Automation GmbH

Holterkamp 18
40880 Ratingen
Germany
T: +49.2102.126.3835
E: sales@xiris.eu

Xiris Automation APAC

Koh Kaew
Phuket 83000
Thailand
T: +66.8.2018.6618
E: sales@xiris.com