



INDUSTRIAL VACUUM SYSTEMS

Product group
Mobile Vacuum Units

BlowVac BackLift



BlowVac BackLift

- ✓ Outstanding performance
- ✓ No compromises in tilting height
- ✓ Highly versatile operation



wieland lufttechnik

Wetterkreuz 12
D-91058 Erlangen
Germany

Phone +49 9131 60 670

Fax +49 9131 60 44 01

info@wieland-luft.com

www.wieland-luft.com

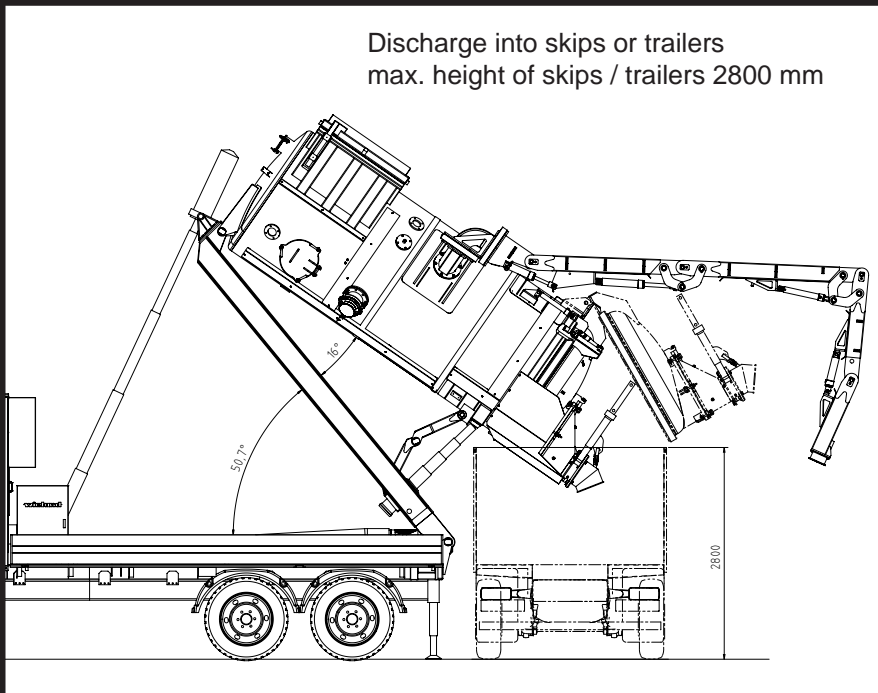
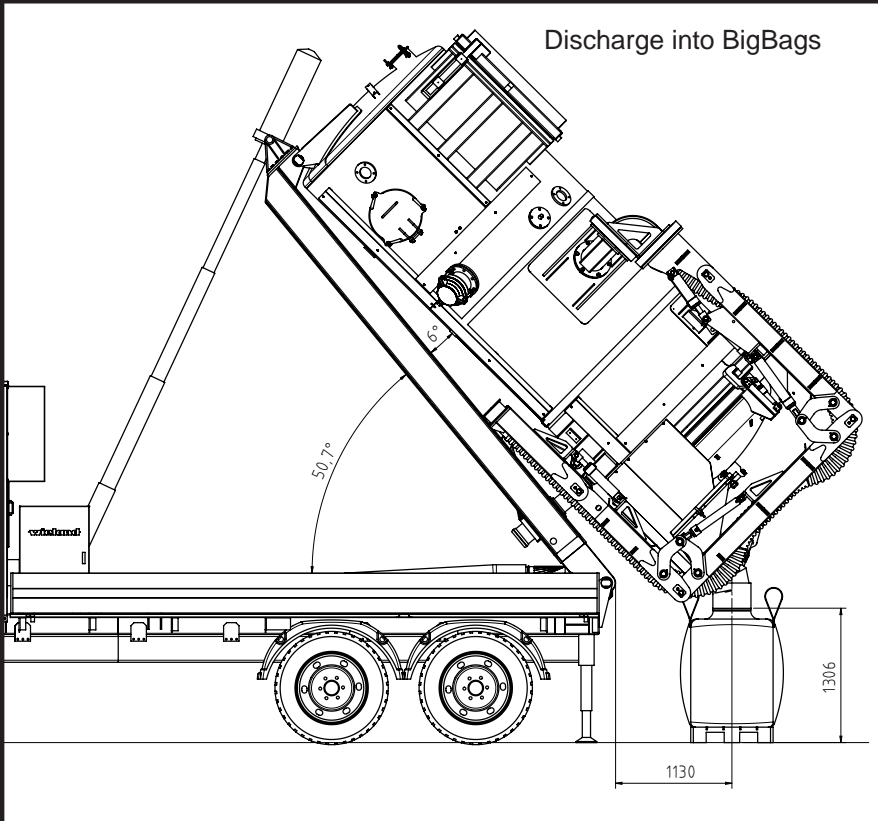

Technical details	Unit	8200	10000
Airflow*	m ³ /h	8200	10000
Suction power max.*	mbar	800	800
Suction inlet	DN	200	200
Collection volume	m ³	10	10
Main filter	m ²	40	50
Safety filter	m ²	40	60

* max. vacuum pump

Suction power at your choice

Depending on your requirements, units with 8200 or 10000 m³/h airflow are available. The overall filter area is increased to 110 m² for units with an airflow of 10000 m³/h in order to realize the full potential of the vacuum pump.

Material discharge at important discharge height

The BackLift system with its sturdy design can lift the collection container to a discharge height of up to 3 m.

Material discharge into BigBags

Mounting of the discharge cone allows for fast and convenient material discharge into BigBags. Material discharge through the blowing device is not necessary. Extremely fast conversion from pressure discharge to BigBag discharge in less than 15 min.

Suction with tilted collection container

The BlowVac BackLift can vacuum extract suction material with the collection container in the lifted and tilted position. This is an important advantage and increases the overall hourly suction and discharge rate tremendously.

Pressure discharge with optimised blowing device

By mounting the conversion cone for pressure discharge, operators can blow out bulk material in an optimal way. The optimized material feed of the system allows for high conveying rates.

Suction work with high performance suction arm

In order to utilize the high airflow (10000 m³/h) with a DN 200 suction hose, a suction arm is available. Its length of 7 m and the overlap height of almost 6 m enable an optimal use with reduced setup time.

Vacuum extraction of liquids

The BlowVac BackLift can be equipped for the suction of liquids so that the mainfilter is protected as far as possible against humidity.



1118-495/1