

GURUTZPE

Slant-bed
lathes

SERIES **GS**



SMART TURNING
SOLUTIONS



Ezina ekinez egina

A look at the future

As **GURUTZPE** continues to grow and evolve, we are thrilled to introduce our latest innovation: the GSM Series. Building on our 65 years of experience in the machine tool industry, the GSM Series is a game-changing solution for integral machining on revolution parts.

We understand the challenges that lie ahead for our customers in the energy, aerospace, oil&gas and other sectors. With the GSM Series, we are ready to accompany our customers in overcoming these challenges with a state-of-the-art technology that meets the highest demands of the market.



Elías Badiola
Managing Director - CEO

At the heart of the GSM Series is a monobloc casting bedway with hardened and ground guideways, designed for maximum rigidity, stability, and precision. The slant design ensures excellent chip evacuation and unbeatable ergonomics for the operators.

Combined with rollers guiding system (Z and X axes) at the machining column and a Y axis hydrostatic (RAM), the GSM Series offers the best rigidity-damping balance on a machining column. This allows for longer life of the inserts, better surface quality, and less demand on the machine's mechanisms in general, resulting in lower maintenance costs and a longer machine life.

With the multitask GSM10/GSM13/GSM16 TurnMills, we offer a complete turning-milling-boring (5 axis) solution that can optimally machine parts up to Ø1.6m, 10m long, and 20 tons. And with a high level of automation, we can finish the workpiece machining on a single set-up, saving time and increasing productivity.

At **GURUTZPE**, we are passionate about our products and committed to delivering outstanding results. With the GSM Series, we offer a wide range of modular solutions, including various spindle motors, chucks, steady rests, and machining heads, allowing us to provide personalized solutions to each client, starting from standard modules.

We look forward to continuing to grow alongside our customers and being their trusted partners in their day-to-day challenges.

Index

- 06. Characteristics
- 12. Head options
- 14. Customization
- 16. Sectors & Applications
- 18. Technical data
- 22. Standard and optional equipment
- 24. Digital

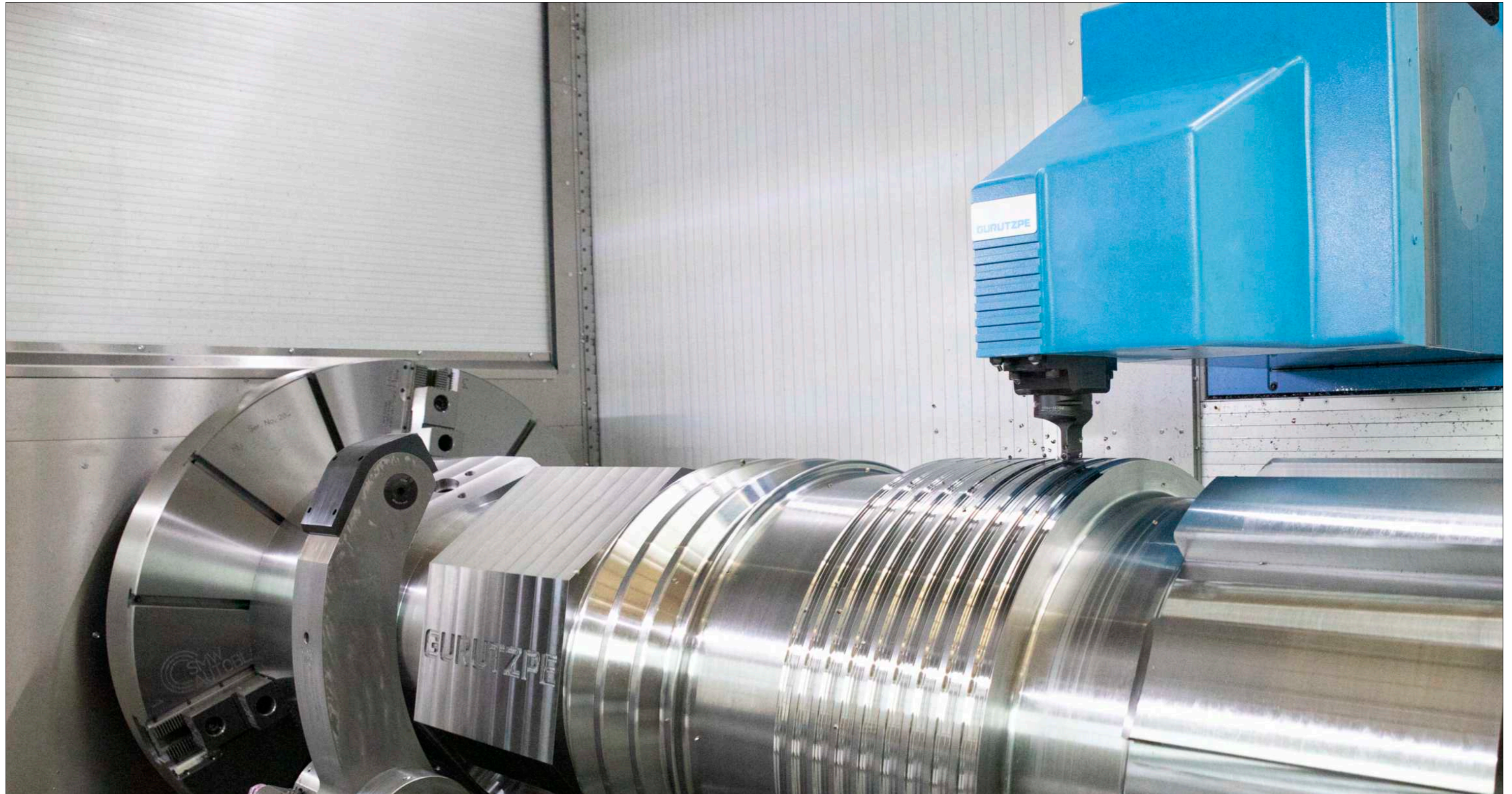

SERIES GS

Slant bed lathes

HS Rollers guides on carriage

R Hydrostatic RAM guiding

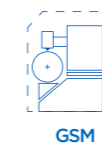

GSM

The Multitask horizontal solutions are based on a monoblock cast-iron slant bed lathe plus a Milling-Boring column, providing the highest stiffness, superior machining accuracy and high operational ergonomics.

CHARACTERISTICS

Robust, Simple, Multitask Machine

Our machine boasts a truly multitask concept, ergonomic design for operator comfort, and exceptional chip shedding capabilities. Its highest level of automation ensures seamless switching between functions while its sturdy construction guarantees long-lasting performance.

Highly customizable and easy to use, this machine offers advanced features, making it an ideal choice for businesses looking to increase efficiency and stay ahead of the competition.

Turning chip section up to **15 mm²**

Milling up to **1300 Nm**

ID turning bar up to **Ø200 mm**



1 Machining column



- › Thermo-symmetric robust design
- › Box-in-box configuration by central RAM
- › RAM with hydrostatic guiding

2 Hydrostatic RAM



- › Unique Multitask lathe with Hydrostatic guides on the RAM, which add important benefits related to usual roller guides:
 - › Much higher vibration dampening.
 - › Much lower wear on guides
 - › Longer tools insert life

3 Machining heads



- › Heavy Milling, interrupt Turning, and Finishing operations
- › Integrated additional clamping systems for multifunction accessories, as ID turning long bars up to Ø200
- › Temperature and vibration monitoring

4 AHC (Auto Head Changer)



- › Powerful heads magazine.
- › Carrousel type boring bars opt.
- › Boring bar up to Ø200

5 Over headstock magazine



- › With independently moving pick-up station per each accessory.
- › Machine foot-print is not increased, while a changer for heads requires additional floor space for the pick-up.
- › Simple system with low risk of failure.

6 ATC (Auto Tool Changer)



- › 50 - 100 tools magazine *
- › Chain type or robot.
- › Up to L=650; W=25 Kg

CHARACTERISTICS

COMPLETE MACHINING PROCESS IN ONE SET-UP

OD machining operations between centers, on the right front and inside with a steady, chucking on the subspindle and finishing on the left front ... all in one clamp, with no manipulation. Safety, speed, quality ... productivity!



Typical complex part machining cycle time:

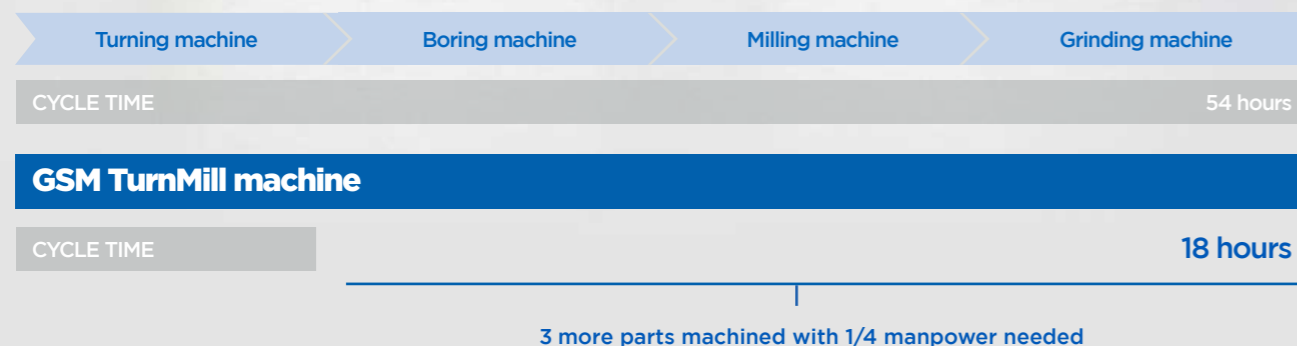

CHARACTERISTICS

MULTITASK



- > OD turning
- > OD heavy turning
- > ID turning up Ø200 Boring bar
- > 5 axis Milling
- > Deep hole drilling
- > ID contour machine with special bar
- > Face operation with facing heads
- > ID groove machining
- > Measurement in Process
- > Cam Milling
- > Gear Hobbing and gear Milling
- > Crankshaft machining
- > Grinding
- > Radial slotting with disk

CHIP REMOVAL



This machine has a direct vertical chip fall to the conveyor and a bed without blind pockets, which can be thoroughly cleaned with wipers on the steadies and tailstock. Depending on the chip shape, the platform grid may need to be redesigned. The machine does not have telescopic backwall guarding, but instead uses aluminum aprons and allows for flushing of the flat surface.

CUTTING FORCES FLOW

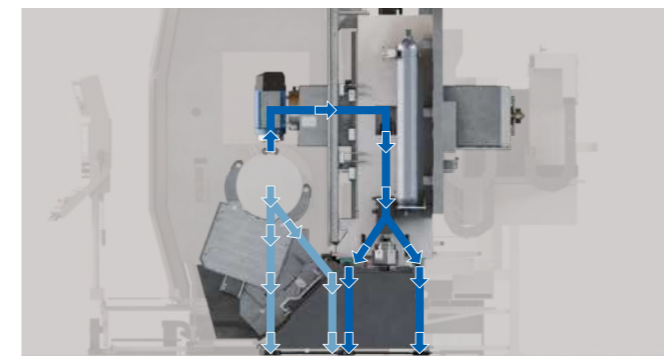

Short and direct flow of cutting forces down to the machine anchoring points, guides thru. 1st guides in the force flow are hydrostatic, which damp most of the vibrations, while roller linear guides on other Multitask lathes hardly damp any. Part's weight is fully aligned with the front anchoring points of the machine to the ground, while it is cantilevering on other Multitask lathes.

ERGONOMICS



This machine features a flat walking surface for operators and a machining spot at eye level. It provides easy access to the chuck, tailstock, steadies and tools, as well as hands-free chuck control. Additionally, it offers an excellent view through windows and is fully covered with inox material internally.

ROBUST STRUCTURE

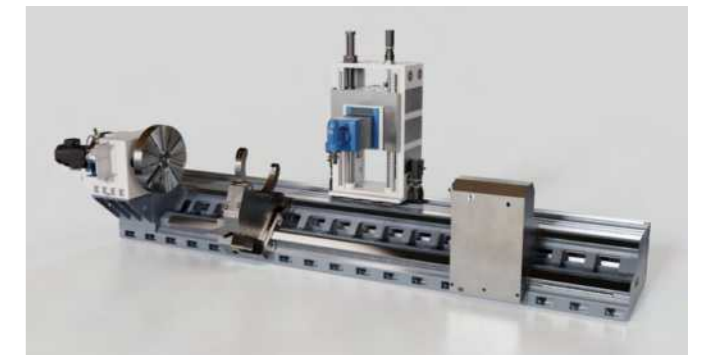

GURUTZPE makes heavy-duty lathes with a sturdy cast iron bed, ground and hardened guides, a backlash-free headstock, and a symmetrical central RAM column. The RAM is hydrostatically damped, and the bed has a 45-degree slant with three fixation lines and ground surfaces for rollers guides.

EASE OF USE



Our SIEMENS 840D control system is user-friendly with pre-built ShopTurn and ShopMill modules for specific cycles. It's ideal for NX-CAM systems, and operating it doesn't require a software engineering background. We've also installed cameras in the machining, ATC, and AHC areas for added convenience.

CHARACTERISTICS

HEAVY machining column

- 1 Symmetric design for optimal thermal and stiffness behavior
- 2 Hydrostatic Box-in-Box configuration for RAM
- 3 520 x 460 / 630 X 460 mm hydrostatic guiding of the RAM
- 4 Y axis external brake for heavy turning and drilling operations
- 5 Combined frontal & lateral 4 guides roller system for X axis
- 6 Hydraulic weight compensation for X axis
- 7 Electronic preload with double pinion rack for Z axis
- 8 Compensation for RAM deflection not needed.

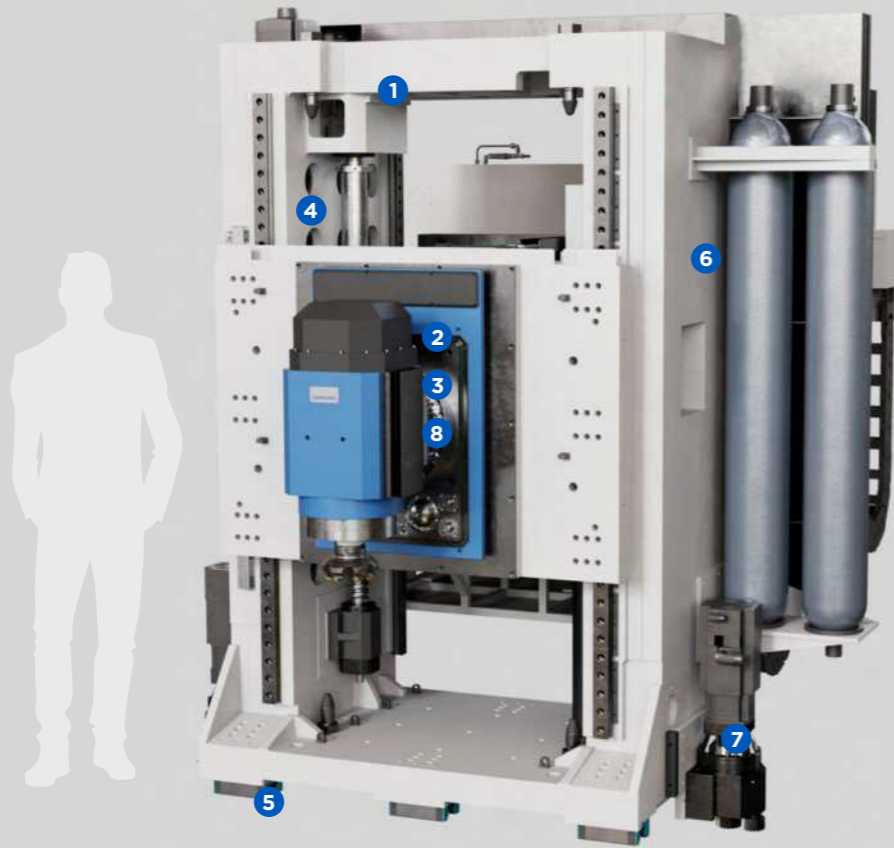

CHARACTERISTICS



HYDROSTATIC RAM SYSTEM

- › Improved vibration absorption and increased rigidity
- › Reduced wear and improved tool insert life
- › Better surface finish with Ra values ranging from 0.4 to 0.8
- › Longer lifespan compared to other roller guides and ball screws
- › Reduced general machine maintenance
- › Longer machine lifespan

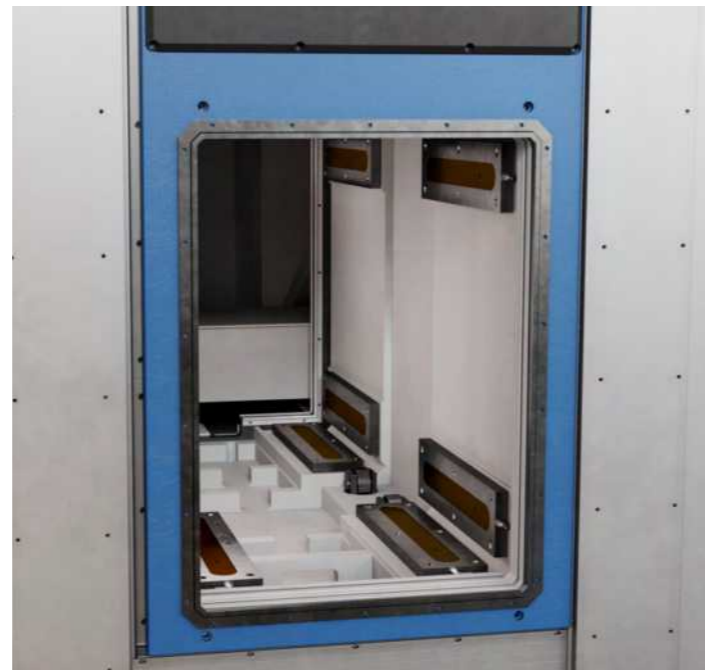

EFFECTS OF DAMPING:

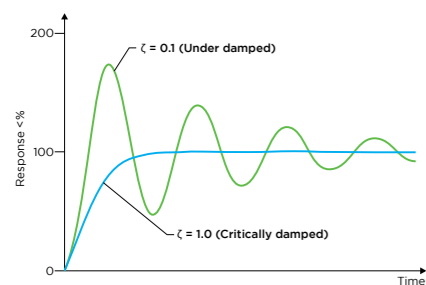

HEAD OPTIONS

Machining heads

GURUTZPE's multifunction heads are robust and reliable, making them an ideal choice for a wide range of machining applications. Whether you need to perform rough milling on forged parts, turn interrupted surfaces, or handle

internal diameters up to 200 mm, these heads deliver precision and power. With their superior engineering and construction, GURUTZPE's heads are designed to provide long-lasting performance even in demanding operations.



STANDARD HEAD

- › Torque (S1): 530 Nm
- › Speed: 8.000 rpm
- › Capto C8 or HSK-T100

Ideal for Medium-Heavy milling / drilling/turning operations.

Tool spindle clamping for Turning heavy cuts, up to 1800 Nm on a Hirth ring.

B-axis continuous 745 or 1540 Nm, with braking system up to 8000 Nm at any position.

HIGH TORQUE HEAD

- › Torque (S1): 1.300 Nm
- › Speed: 6.000 rpm
- › Capto C8 or HSK-T100

Ideal for Heavy-Duty milling / drilling/turning operations.

Tool spindle clamping for Turning cuts, up to 1800 Nm on a Hirth ring.

B-axis continuous 1540 Nm, with braking up to 8000 Nm at any position, and clamping 20.000 Nm each 2.5°

HIGH SPEED HEAD

- › Torque (S1): 160 Nm
- › Speed: 18.000 rpm
- › Capto C6 or HSK-T63

Ideal for milling /drilling/turning operations in Aluminum, Fiber glass, Composite, HRSA and similar alloys.

Tool spindle clamping for Turning cuts.

B-axis continuous 850 Nm, with braking system up to 8000 Nm at any position.

HEAD ASSEMBLY CONFIGURATIONS



MONOBLOCK HEAD



INTERCHANGEABLE HEAD

HEAD OPTIONS

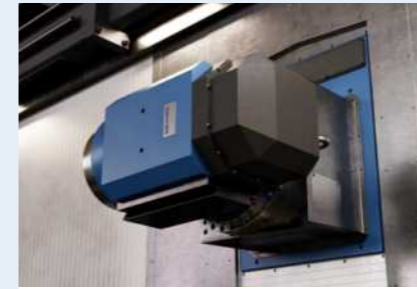

B-AXIS PRISMATIC CLAMPING SYSTEM FOR ROTARY TOOLS AND ACCESSORIES

System for the tools and machining accessories that exceed the maximum dimensions of the chain type or robot-based ATC. Thanks to the long and wide prismatic clamping system, long solid/Ejector drills, angular/facing heads and U-axis boring bars can be rigidly fixed to the milling unit. The use of this clamping system opens up the possibility of automatically changing the tools on the angular/facing heads. For the automatic handling of these tools and accessories, a magazine is available above the headstock.



RAM DOCKING SYSTEM FOR STATIONARY HEAVY ACCESSORIES

Optional bigger RAM, equipped with automatic docking elements in its bottom section. High force docking elements allow to clamp boring bars up to Ø150 mm, 2.100 mm length and 400 kg. B-axis is free of heavy loads, and there is no need for one additional saddle dedicated to the heavy accessories. A magazine is available above the headstock for automatic handling of these stationary heavy boring bars, besides the rotating accessories



RAM DOCKING SYSTEM FOR CHANGE OF MACHINING HEADS

Another optional RAM type for automatic change of heavy-duty machining heads. It is equipped with very high force docking elements in its four corners, which allow boring bars up to Ø200 / 2.800 mm length, and machining heads up to 600 kg. For automatic changing of heads, an independent pick-up magazine is available on the tailstock side



U-AXIS FACING HEAD



TURNMILL HEAD



U-AXIS INTERNAL BORING BAR



BORING BAR Ø150 MM



BORING BAR Ø200 MM



ANGULAR INTERNAL SLOTTING HEAD



HEAVY TURNING HEAD



HEAVY TURNING HEAD



DEEP HOLE DRILLING EJECTOR HEAD



HEAVY FACE TURNING HEAD



GRINDING HEAD

CUSTOMIZATION

Automatic system

ATC_{CHAIN}

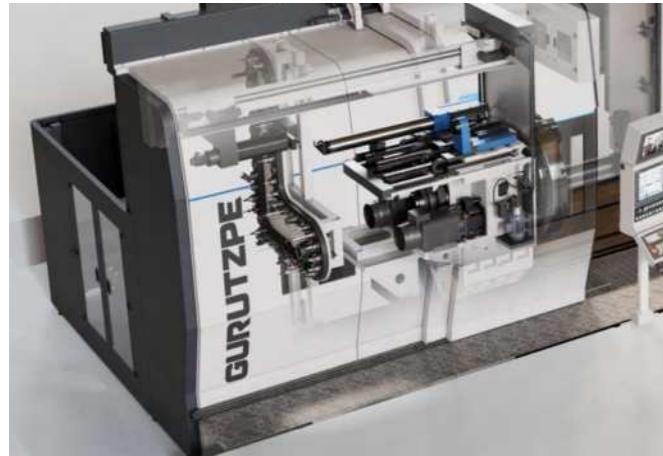

CHAIN TYPE FOR HORIZ TOOL CHANGE, LENGTH AND WEIGHT LIMITED

ATC_{ROBOT}

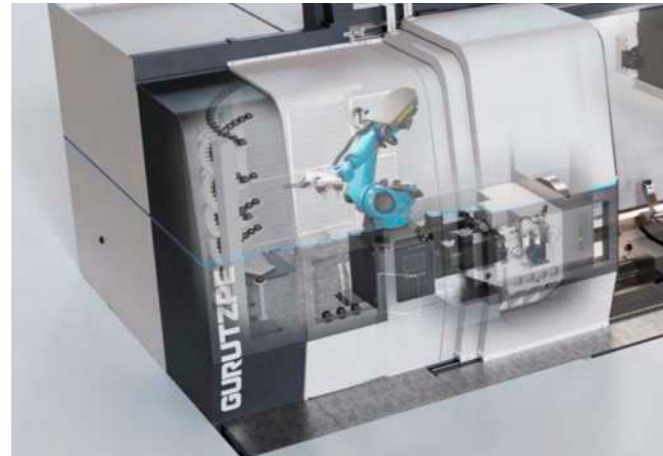

ROBOT TYPE HORIZ & VERT TOOL CHANGE, L<800mm; W<35 kg

OVER HEADSTOCK MAGAZINE

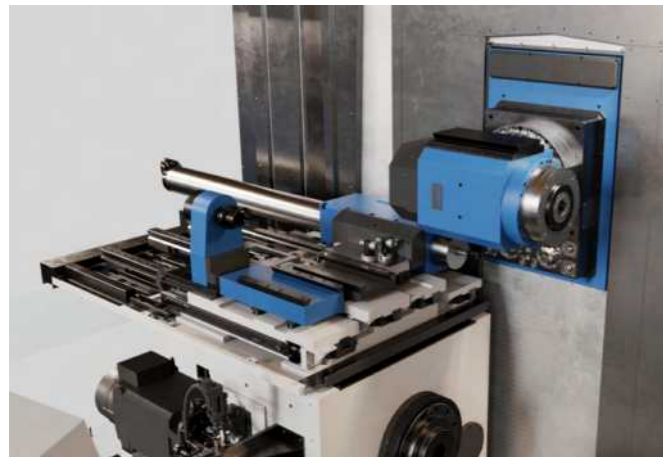

4 configurable rails. Each utility of these rails are defined according to customer needs.

AHC

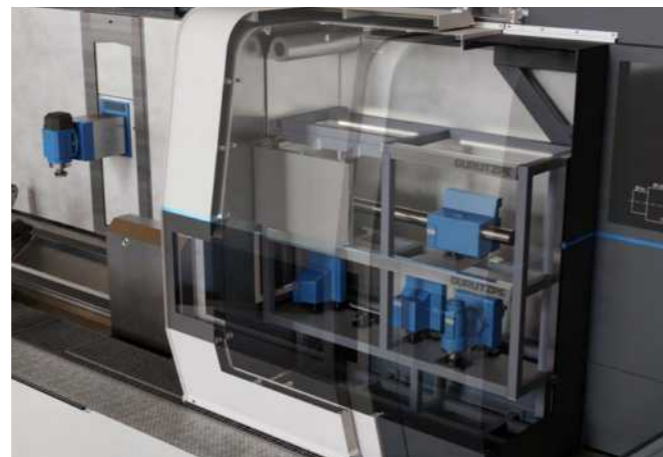

CUSTOMIZATION

Others



CHUCKS

MANUAL CHUCK WITH INDEPENDENT JAWS

HYDR. SELF-CENTERING CHUCK 3/4/6 JAWS

SELF-CENTERING AND FLOATING HYDR. PLATE 3 JAWS



STEADY RESTS



SELF-CENTERING HYDRAULIC STEADY REST



MANUAL STEADY REST



HYDROSTATIC STEADY REST



TAILSTOCK



TAILSTOCK



SUBSPINDLES



PROBES



PROBE IN MACHINING HEAD



CALIBRATION PROBE TOOL FOR TURNMILL UNIT



CALIBRATION PROBE TOOL FOR TURNMILL UNIT

SECTORS & APPLICATIONS

GURUTZPE has developed a range of machining solutions tailored to the specific needs of each company and sector. This involves developing unique machines specific to each sector.

Our extensive history in implementing machining solutions has allowed us to design specially adapted machines and solutions for a wide range of sectors.



SECTORS & APPLICATIONS

1. Power Generation



TURBINES



GAS TURBINE ROTOR



TURBO GENERATOR SHAFT

2. Aerospace



AERO TURBINE SHAFT



LANDING GEAR



LANDING GEAR

3. General industry



CRANKSHAFT



STEEL ROLLS



REDUCER SHAFT

4. Oil & Gas



SUBSEA WELLHEAD



TUBING HANGER



DRILLING SPOOL

5. Paper and printing



ROLLER SHAFTS



PRINTING ROLL



PAPER DEVANATOR SHAFT

6. Industrial machinery



TWIN SCREW EXTRUDER BARREL



HYDRAULIC CYLINDERS

TECHNICAL DATA

	Un.	GSM10	GSM13	GSM16	
WORKPIECE & CAPACITIES	Swing over Bed	mm	1000	1300	1600
	Workpiece Max. Length between centers = BC	mm	6000 / 8000	8000 / 12000	10000 / 13000
	Workpiece Max. Weight between centers	kg	up to 8000	up to 15000	up to 20000
	Z-axis stroke	mm	BC + 250	BC + 250	BC + 250
	X-axis stroke	mm	+1025 / -25	+1175 / -25	+1325 / -25
	Y-axis stroke	mm	+300 / -300	+350 / -350	+400 / -350
TURNING SPINDLE	Spindle coupling DIN 55026 size	size	A11 / A15	A15 / A20	A15 / A20
	Spindle inner bore Ø	mm	Ø110 / Ø150	Ø150	Ø150
	Spindle front bearing inner Ø	mm	Ø200 / Ø240	Ø240 / Ø300	Ø240 / Ø300
	Max. Power S1-100% / S6-60%	kW	74 / 90	102 / 130	102 / 130
	Max. Torque S1-100% / S6-60%	Nm	9420 / 11460	16155 / 21540	27525 / 36700
	Max. Spindle Speed	rpm	1500	1500 / 1200	1200 / 700
	C-axis positioning speed	rpm	15	15	15
	C-axis max. Torque	Nm	7000	7000 / 8500	7000 / 8500
	C-axis min indexing increment	°	0,001	0,001	0,001
TAILSTOCK	Quill Ø	mm	Ø180 / Ø220	Ø220 / Ø280	Ø220 / Ø280
	Quill travel	mm	200	200 / 250	200 / 250
	Live center	size	ISO 50 custom.	ISO 50 / ISO 60 custom.	ISO 50 / ISO 60 custom. / M80
	Chuck adaption coupling DIN 55026	size	A8	A8 / A11	A8 / A11
	Max. Feed force, adjustable by NC (hydraulic drive)	kN	40 / 60	60 / 95	60 / 95 / 125
	Bed Width	mm	1450	1700	1975
	Tailstock and steady-rest friction guides		500 mm distance	635 mm distance	780 mm distance
STEADY-RESTS	Swing over Steady-rest slides	mm	1000	1300	1600
	Hydraulic self-centering roller steady-rest, Max. clamping Ø	mm	800	910	910
	Manual roller steady-rest, C-type, Max. clamping Ø	mm	900	1150	1300
	Hydrostatic steady-rest	mm	With three quills (central hydrostatic), or customized monoblock pads		
MILLING, DRILLING B-axis HEAD	Max. Power S1-100% duty cycle	kW	49 / 56 / 60 / 85		
	Max. Torque S1-100% duty cycle	Nm	1410 / 305 / 165 / 530		
	Max. Spindle Speed	rpm	5000 / 6000 / 18000 / 8000		
	Tooling interface	size	C8 or HSK-T100 / C6 or HSK-T63		
	B-axis swiveling	degrees	310		
	B-axis smallest programmable increment	degrees	0,001		
	B-axis positioning Continuous Torque for 5-axes machining (S1-100%)	Nm	745 / 850 / 1535		
	B-axis positioning Speed	rpm	40		
	B-axis Braking Torque each 0.001°	Nm	4000		
	B-axis Locking Torque each 2.5° for Heavy-Duty machining, by a Hirth ring	Nm	15000 / 20000		
MILLING, DRILLING COLUMN	Z-axis Turning/milling column, distance between linear guides	mm	720	850	975
	X-axis vertical saddle, distance between linear guides	mm	1230	1230	1230
	Y-axis RAM-1, standard version	mm	460 x 520	460 x 520	460 x 520
	Y-axis RAM-2 with bottom docking system for non-rotary accessories	mm	460 x 630	460 x 630	460 x 630
	Y-axis RAM-3 with docking system for change of machining heads	mm	550 x 520	550 x 520	550 x 520
	Y-axis guiding		Hydrostatic		
	Feeding force Z-axis, S1-100%	kN	40	50	70
	Feeding force X-axis, S1-100%	kN	30	30	30
	Feeding force Y-axis, S1-100%	kN	30	30	30
	Braking force Y-axis, out of the motor	kN	35	35 / 50	35 / 50
	Rapid feed Z-axis	m/min	20	20	17,5
	Rapid feed X-axis	m/min	20	20	20
	Rapid feed Y-axis	m/min	20	20	20

TECHNICAL DATA

	Un.	GSM10	GSM13	GSM16	
TOOL MAGAZINE	Chain type tool magazine	Posts	50 / 80 / 100		
	Max. Diameter of tools	mm	125 and 250 with empty adjacent pockets		
	Max. Length of tools	mm	600 / 750		
	Max. Weight of tool	kg	25 / 30		
	Robot type tool magazine	No	100		
	Max. Length of tools	mm	850		
	Max. Weight of tool	kg	35		
Tool identification system		RFID tags on tools and reading/writing system in the machine			
OTHER MAGAZINES	Accessories magazine over the Headstock		Up to 4 automatic sliding posts, accessory max. Ø150 mm and 2300 mm length		
			Covers for the docking and prismatic systems are on these posts		
	Heads pick-up magazine on the right end of the Tailstock		Up to 4 Heads and a boring bar max. Ø200 mm and 3200 mm length		
CHIP & COOLANT	Chip conveyor discharge height	mm	1130		
	Internal coolant pump pressure and flow	bar - l/min	20 bar - 50 l/min Optional 70 bar or 200 l/min		
	External coolant pump pressure	bar	8		
MACHINE DIMENSIONS	Dimensions for 3000 mm. BC: Length (without conveyor) x Width (without HMI panel & with electric cabinet) x Height	mm	10700 x 5100 x 4450	11200 x 5700 x 4850	11700 x 6300 x 5450
	Weight Total without conveyor (approx.)	kg	47500 (3m)	54000 (3m BC)	83000 (6m BC)
	Weight increase per each 1000 mm BC	kg	1200	1800	2200
OTHERS	CNC		Siemens ONE as standard (Fanuc as option)		
	HMI screen		19" LCD colour display		
	Painting	RAL	Grey RAL-7024 structural stationary elements Lightgrey RAL-7035 main moving components Blue RAL-5012 machining heads and accessories Blued the U-axis head		

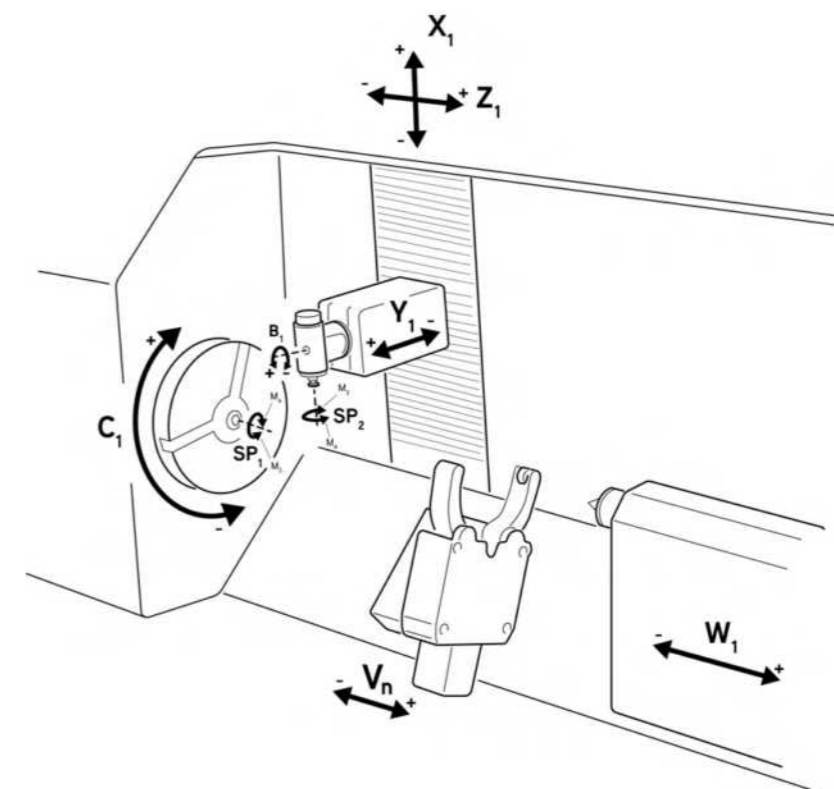

TECHNICAL DATA

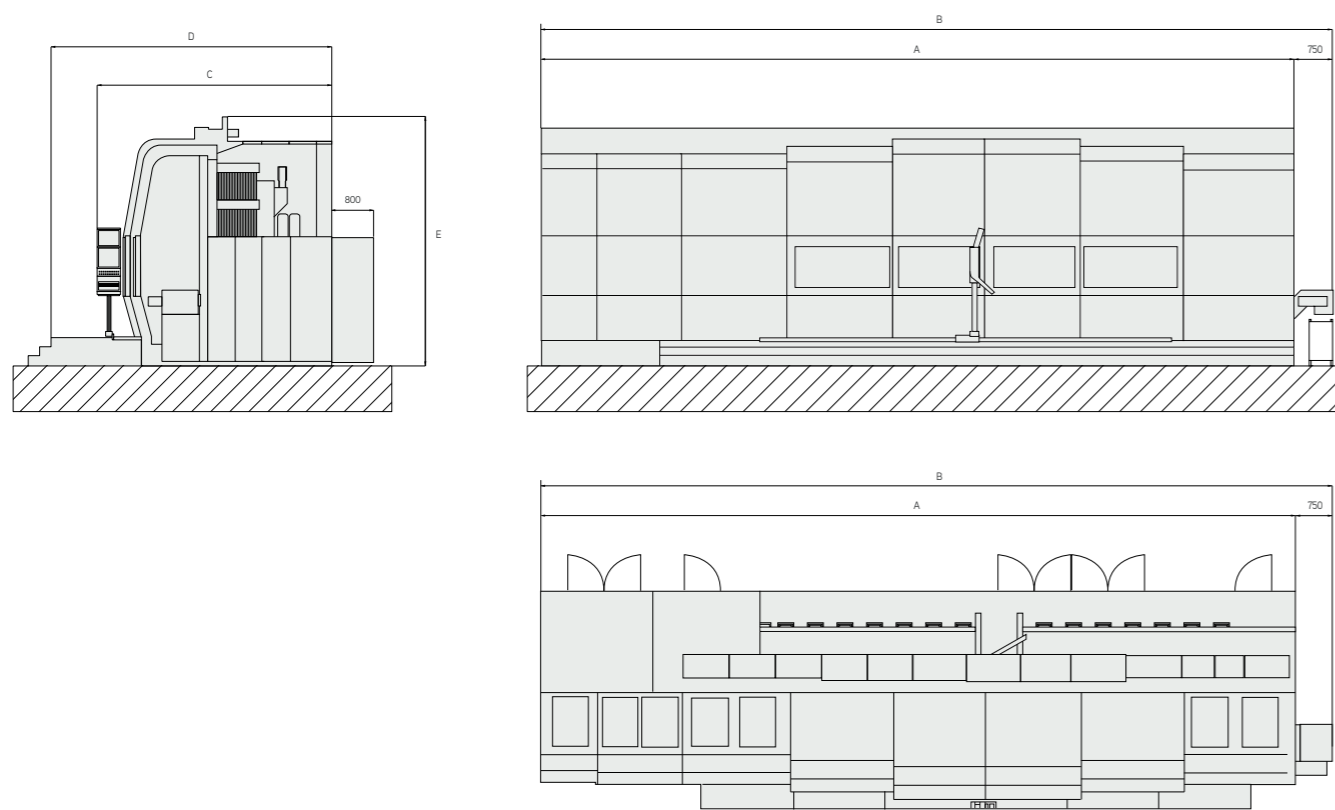

		GSM10	GSM13	GSM16
C	mm	4.800	5.200	7.000
D	mm	5.600	6.000	7.800
E	mm	4.450	4.850	5.450

GSM10 MACHINE LENGTH (values without head changing magazine)							
Between centers	mm	3.000	4.000	5.000	6.000	7.000	8.000
A	mm	10.700	11.700	12.700	13.700	14.700	15.700
B	mm	11.450	12.450	13.450	14.450	15.450	16.450

GSM13 MACHINE LENGTH (values without head changing magazine)							
Between centers	mm	3.000	4.000	5.000	6.000	7.000	8.000
A	mm	12.000	13.000	14.000	15.000	16.000	17.000
B	mm	12.750	13.750	14.750	15.750	16.750	17.750

GSM16 MACHINE LENGTH (values without head changing magazine)							
Between centers	mm	3.000	4.000	5.000	6.000	7.000	8.000
A	mm	12.500	13.500	14.500	15.500	16.500	17.500
B	mm	13.250	14.250	15.250	16.250	17.250	18.250

TECHNICAL DATA

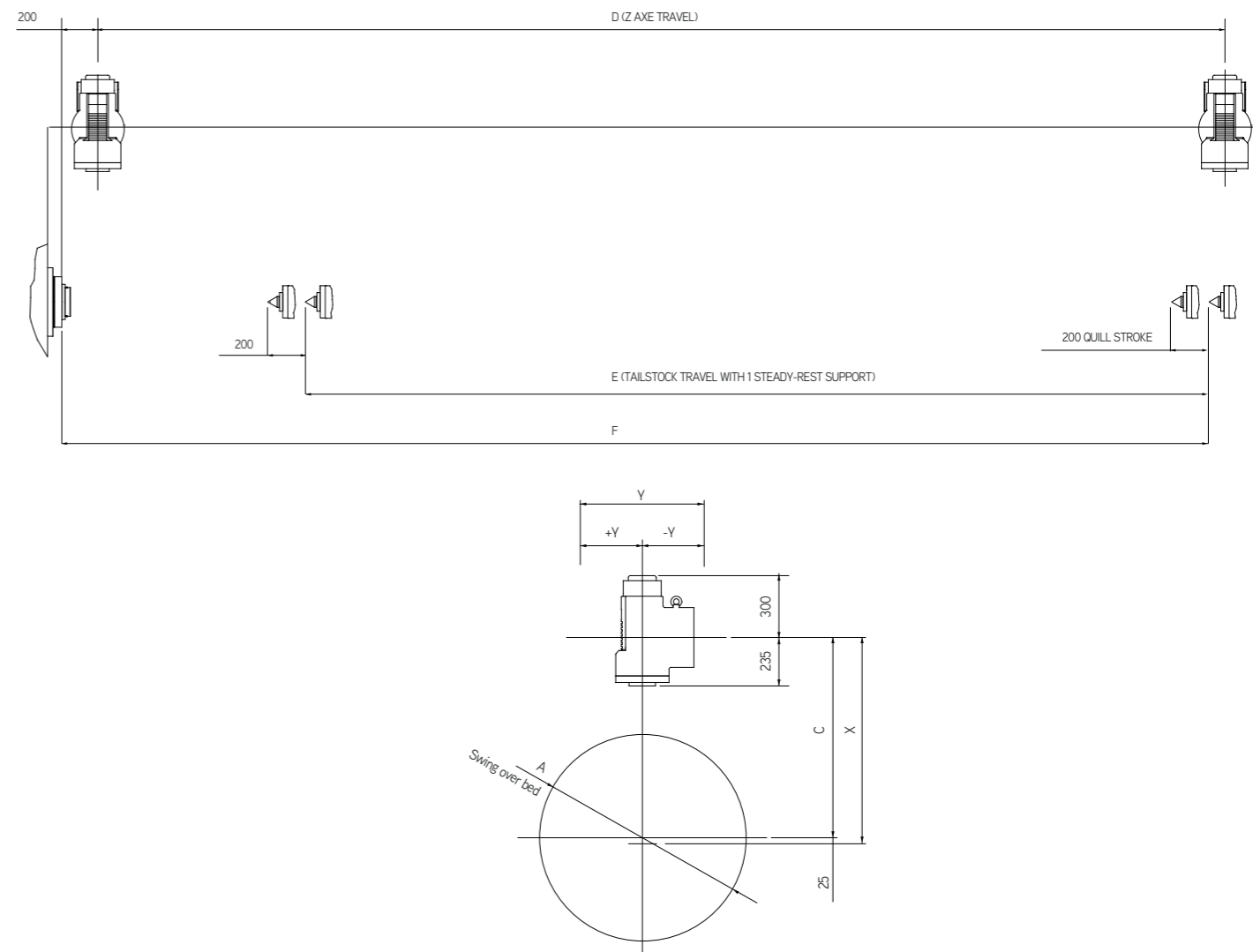

MACHINE LENGTH							
Between centers	mm	3.000	4.000	5.000	6.000	7.000	8.000
D	mm	3.250	4.250	5.250	6.250	7.250	8.250
E	mm	2.000	3.000	4.000	5.000	6.000	7.000
F	mm	3.350	4.350	5.350	6.350	7.350	8.350

		GSM10	GSM13	GSM16
A (Swing over bed)	mm	1.000	1.300	1.600
B (Swing over steady carriage)	mm	1.000	1.300	1.300
X (Travel axe X)	mm	1.050	1.200	1.350
Y (Travel axe X)	mm	+300/-300	+350/-350	+400/-350

STANDARD AND OPTIONAL EQUIPMENT

	Equipment	Options	GSM10	GSM13	GSM16
01. HEADSTOCK	Main Turning Spindle	Spindle bore Ø110, Bearing inner Ø200, coupling A11, up to 6 tons	■	□	✕
		Spindle bore Ø150, Bearing inner Ø240, coupling A15, up to 8 tons	□	□	□
		Spindle bore Ø150, Bearing inner Ø240, coupling A15, up to 10 tons	▲	■	□
		Spindle bore Ø150, Bearing inner Ø300, coupling A20, up to 15 tons	□	□	□
		Spindle bore Ø150, Bearing inner Ø300, coupling A20, up to 20 tons	✕	✕	■
	Max. Turning Power, Torque and rpm by two motors in tandem drive (S1/S6)	74/92 kW, 9.42/11.46 kN, 1500 rpm	■	□	□
		102/136 kW, 11.6/15.5 kN, 1200 rpm	✕	■	□
102/130 kW, 16.2/21.5 kN, 1200 rpm		✕	□	■	
102/130 kW, 27.5/36.7 kN, 700 rpm		✕	✕	□	
02. TAILSTOCK OR SUBSPINDLE	Quill	Rotating quill Ø180 mm, 200 mm stroke, up to 6 tons	■	□	✕
		Rotating quill Ø220 mm, 200 mm stroke, up to 8 tons	□	□	□
		Rotating quill Ø220 mm, 200 mm stroke, up to 10 tons	▲	■	□
		Rotating quill Ø280 mm, 250 mm stroke, up to 15 tons	✕	□	□
		Rotating quill Ø280 mm, 250 mm stroke, up to 20 tons	✕	✕	■
	Subspindle Max. Turning Power, Torque and rpm by two motors in tandem drive (S1/S6)	44/66 kW; 1500 rpm	□	□	□
		74/92 kW, 9.42/11.46 kN, 1500 rpm	✕	□	□
03. STEADY-RESTS	Hydraulic self-centering biggest steady-rest	Ø300-800, 4500 daN clamping force per roller	□	□	□
		Ø650-910, 8500 daN clamping force per roller	✕	□	□
		Ø800-1100; 8 tons	✕	□	□
	Manual biggest steady-rest, C-type	Ø600+900; 4,5 tons; fixed to the sliding saddle	□	□	□
		Ø800+1300; 8 tons; fixed to the bed	✕	✕	□
	Hydrostatic Manual steady-rests	Variety of clamping ranges and weights	▲	▲	▲
04. MACHINING COLUMN	RAM type	Section 460x520 mm without automatic docking system	■	□	□
		Section 460x630 mm with automatic docking system for non-rotating heavy accessories (lower section of the RAM), included boring bars up to Ø150 mm	□	■	□
		Section 550x520 mm with automatic docking system for change of machining heads and boring bars up to Ø200 mm	▲	□	■
	High flow Coolant on top of the RAM	Up to 200 l/min for for Deep Hole Drilling, by a quick manual connector	□	□	□
		Up to 100 l/min for Grinding, by a quick manual connector	□	□	□
	Electric signal connections for Monitoring machining accessories	For angular heads, added in the B-axis spindle	□	□	□
		For non-rotary accessories, included in the lower automatic docking system	□	□	□
Electric Power connections on top of the RAM	For U-axis heads, power and signal connections by one quick manual connector	□	□	□	
05. MILLING TURNING B-AXIS HEAD	Standard B-axis head	85 kW, 531 Nm, 6000 rpm, tool interface C8 or HSK-T100	■	■	□
		60 kW, 165 Nm, 18000 rpm, tool interface C6 or HSK-T63	■	■	□
		49 kW, 1410 Nm, 5000 rpm, tool interface C8 or HSK-T100	□	□	■
	Automatically changeable tool spindle	Interchangeable on the same B-axis spindle, that keeps into the RAM	□	□	□
	Monitoring and Protection system of the B-axis head	Collision and vibration alarms, Temperature warning	■	■	■
	Prismatic clamping system for rotary tools and accessories	Added on a side of any B-axis head	□	□	□

STANDARD AND OPTIONAL EQUIPMENT

	Equipment	Options	GSM10	GSM13	GSM16
06. TOOL MAGAZINE	Chain type carousel with a linear transfer and changing arm; max. tool L=600 mm, Ø125mm, 25Kg	50 tools; tool interface C6/HSK-T63 or C8/HSK-T100	■	□	□
		80 tools; tool interface C6/HSK-T63 or C8/HSK-T100	□	■	□
		100 tools; tool interface C6/HSK-T63 or C8/HSK-T100	□	□	■
	Chain type carousel with a linear transfer and changing arm; max. tool L=750 mm, Ø125mm, 30Kg	50-80-100 tools	□	□	□
		Robot type; max. tool L=800 mm, Ø125mm, 35Kg	100 tools; tool interface C6/HSK-T63 or C8/HSK-T100	□	□
	Tool identification system	For chain type ATC, RFID reading and writing system is on the way between the machining spindle and the carousel	□	□	□
07. MACHINING HEADS AND ACCESSORIES	Lower section of the RAM with automatic docking system for non-rotating heavy accessories	Heavy Turning heads, with automatic C8, radial or axial toolholder	□	□	□
		Boring bars up to Ø150 mm and 2300 mm length			
		Ejector deep hole drilling tools	□	□	□
	B-axis head with prismatic clamping system for rotary tools and accessories	Ejector deep hole drilling tools, depending on tool size and cutting forces	□	□	□
		Angular long heads for internal milling	□	□	□
	U-axis heads		□	□	□
	Grinding head, depending on wheel size		□	□	□
	RAM with integrated automatic docking system	Boring bars up to Ø200 mm and 3200 mm length	▲	□	□
		Grinding head	□	□	□
	08. MAGAZINES FOR ACCESSORIES AND HEADS	For Accessories, a magazine with automatic independent sliding posts over the Headstock	Up to 4 posts; accessory max. Ø150 mm and 2300 mm length	□	□
Tool measuring laser and probing unit on one of the posts			□	□	□
Covers for docking and prismatic systems on these posts			□	□	□
For Heads, a pick-up magazine on the right end of the Tailstock		Up to 4 Heads and a boring bar max. Ø200 mm and 3200 mm length	▲	□	□
09. COOLANT SYSTEM AND CHIP CONVEYOR	Coolant tank 1500 l, 20 bar internal / 8 bar external		■	■	■
		Coolant paper filtering, magnetic separator and oil skimmer	■	■	■
	Coolant high pressure pump up to 70 bar	□	□	□	
	Coolant high flow pump up to 200 l/min and higher volume tank, for for Deep Hole Drilling operations	□	□	□	
	Chiller for coolant		□	□	□
10. CNC AND OTHERS	CNC	Siemens ONE	■	■	■
		Fanuc	□	□	□
		Fagor	▲	▲	▲
	HMI screen	19" LCD colour screen	■	■	■
Camera	Over the HMI screen	□	□	□	
11. ENCLOSURE AND AUXILIARY EQUIPMENT	Automatically cleaned windows	Two Visiport windows, one on each door	■	■	■
	Fume extraction system		■	■	■
	Operator front platform		□	□	□
	Coolant gun		■	■	■

■ standard □ optional ✕ no ▲ consult

DIGITAL

Software and digital solutions

GURUTZPE optimizes machining processes, extends the working life of your machine, and reduces operating costs.

01. OPTIMIZED SCREENS

GURUTZPE customised screens that simplify and improve the user experience:

- > Management of coolant
- > Collection
- > Axis consumption

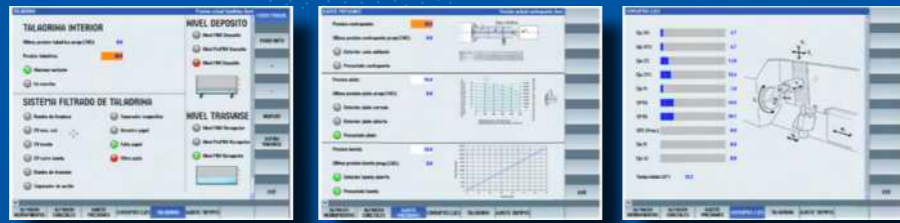

02. APPLICATIONS

Parameter support for programming, machining, and measuring cycles for particular and complex applications. Specific solutions for a range of sectors: railway, lathe-notching, measuring...



GRINDING

SENSOR PARTS & TOOLS

03. ELECTROSPINDLES MONITORING



A SPINDLE CHECK-UP

Enables spindle life time function and statistical data download.



COLLISION ALARM

On collision alarm ITBS digital output is activated in less than 1ms. Collision alarm and warning limits are configurable



TEMPERATURE WARNING

On temperature alarm ITS digital output is activated. Temperature alarm and warning limits are configurable



LOW POWER MODE

Low power mode enables continuous monitoring. It is active while machine is powered off. Requires ITBS PRO Interface



VIBRATION ALARM

On vibration alarm ITBS digital output is activated in less than 1ms. Vibration alarm and warning limits are configurable

DIGITAL

04. ADVANCED TECHNOLOGIES



ADAPTIVE CONTROL

GURUTZPE's adaptive control automatically adjusts the cutting parameters according to the actual machining situation.



LOAD MONITORING

The system runs the most appropriate machine action (e.g., machine alarm or feed hold) whenever machining conditions change.



HEADSTOCK SWIVEL

Automatic headstock speed control to drastically reduce machine vibrations.



TOOL RETRACT

The tool retracts automatically according to defined settings (broken tool, load monitoring, etc.), and repositions itself to restart machining.



CHIP BREAKER

Programmable oscillation in tool movement, breaking chips by interrupted cutting effect.

05. INDUSTRY 4.0

GURUTZPE offers a complete monitoring package that helps improve machine performance and increase process productivity, reducing operating costs.

PREVENTATIVE & PREDICTIVE MAINTENANCE

Optimal reduction of operational and maintenance costs. User's guide for maintenance tasks and machine performance tests (roundness, linearity).

Fast, automated procedure under controlled conditions to regularly monitor the condition of your **GURUTZPE** lathe.

Mathematical and statistical models and computations to obtain the data necessary to estimate/predict anomalous behaviour.

OEE (OVERALL EQUIPMENT EFFECTIVENESS)

Machine productivity indicators. We define the KPIs in accordance with each customer's needs, thus ensuring greater control over production:

- > Machine availability
- > Efficiency
- > Production
- > Consumption





inzu
group

GURUTZPE is part of the internationally renowned INZU Group, which is made up of highly specialist companies in a range of areas in the machinery manufacturing sector: Etxetar, Gaiandu, Aingura and more.

Etxetar

Talens

Gaiandu



#SoCe



ekonek

ikergune

ezarri



www.inzugroup.com

Gurutzpe Turning Solution, S.L.
Pol. Ind. Itziar Q8
20829 Itziar-Deba (Spain)
T. (+34) 943 199 080
www.gurutzpe.com

www.gurutzpe.com